

Electrically Released Brake ER-375, ER-475, ER-650 with Pin Drive Armatures

P-253
819-0315

Installation Instructions



 **Warner**
Electric

An Altra Industrial Motion Company

Contents

Introduction	.2
Installation Instructions	.3
Power Supplies/Brake Release Adjustment	.4
Autogap Adjustment	.5
Operating Instructions	.6
Dimensions and Specifications	.8
Bushing Part Numbers	.9
Exploded View	.10
Component Parts/How to Order	.11
Warranty	Back Page

⚠ WARNING Failure to follow these instructions may result in product damage, equipment damage, and serious or fatal injury to personnel.

Introduction

This service manual tells how to install, adjust, and maintain your Warner Electric brake. It also contains information for part replacements when needed.

Warner Electric Electrically Released Brakes are high performance, high torque units. After carefully reading these instructions, no assembly or installation difficulties should be encountered. Warner Electric Electrically Released brakes function on the same principle of "response to magnetic attraction" that operates other Warner Electric brakes and clutches. Braking torque in these brakes depends on ceramic permanent magnets which have a high resistance to demagnetization. With the power off, the unit produces full braking torque. The brake is released by generating an electromagnetic field which opposes the field produced by the permanent magnets.

Basic Mechanical Considerations

Electrically released brakes require special mounting considerations. Please review the items listed below prior to starting installation per Step 1.

- a) If the magnet mounting surface is a magnetic material, the magnet must be insulated approximately 1/2 inch from that surface with a plate or spacers of non-magnetic material.
- b) Caution must be exercised when the armature is moved close to the magnet assembly since the permanent magnets create a very strong attractive force. Injury may result if fingers are in between the armature and magnet when the gap is 1/2" or less.

Installation Instructions

A. Customer Shall Maintain:

1. Squareness of brake mounting face with armature hub shaft within .006 T.I.R.
2. Concentricity of brake mounting pilot diameter with armature hub shaft within .010 T.I.R.



Figure 2

B. Mounting the Magnet

The brake magnet is mounted to a stationary machine member by a flange. Extreme care must be taken in selecting the location for the mounting of the magnet. Proper positioning is very important for the unit to function correctly.

1. A pilot diameter on the mounting surface is essential to hold the magnet within the required tolerances. (See Figure 1)

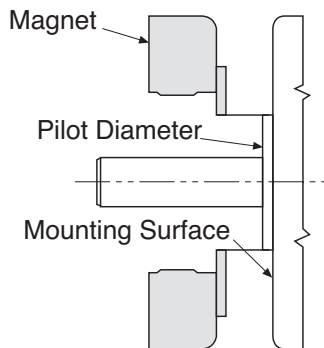

Figure 1

2. A machined pilot diameter is provided on the magnet mounting flange (See Figures 1, 2, & 3) to aid in the proper positioning of the magnet.
3. Once the mounting surface has been prepared the magnet is bolted in place with capscrews and lockwashers. (See Figure 2)

4. Use a dial indicator to check the unit for concentricity and squareness to the shaft. The unit should be concentric within .010 T.I.R. and square within .006 T.I.R. (See Figure 3)



Figure 3

C. Armature To Shaft Assembly

Check to insure that all parts are clean and free from burrs or chips. Insert the key into the shaft keyway. Place the bushing into the hub and match half holes to make complete holes. Each hole will be threaded on one side only. Place the screws loosely into the holes which are threaded on the hub side. Slip the assembly onto the shaft and position it so the armature is in contact with the magnet.

⚠CAUTION Keep fingers clear of area between the magnet and the armature as the armature will be pulled sharply toward the magnet after the gap is closed to approximately 1/8 inch.

Tighten the screws alternately and evenly until all are pulled up very tightly. Tap against the large end of the bushing with a plastic hammer to avoid damaging the bushing. The screws can then be tightened again, using the following torque specifications:

ER-475	55 in. lb.
ER-650	175 in. lb.

Repeat this alternate tapping and retightening until the specified wrench torque no longer turns the screws.

To disassemble, remove both screws and reinsert one screw in the vacant hole (threads on bushing). Tighten this screw until the bushing is loosened in the hub. If the bushing does not loosen, tap on the hub.

D. Power Supplies

The ER style electrically released brakes are designed to operate with an adjustable voltage power supply because the voltage at which the individual brakes will release can vary slightly from brake to brake. The output voltage needs to be adjusted to obtain the optimum release point. Warner Electric offers two different model power supplies, either of which can be used to operate the ER style brakes. They are the MCS-103-1 or the CBC-200. Refer to the control operation manual for instructions on how to wire the control.

E. Brake Release Adjustment

Instructions for setting the optimum release voltage of permanent magnet applied/electrically released brakes.

CAUTION The following procedure will result in the brake releasing and allowing the load to be free to move. Be sure the load is in a safe condition before proceeding with this process.

In a permanent magnet applied/electrically released brake, the attractive force between the

brake surfaces is created by permanent magnets. The brake is electrically released by applying DC power to the electro-magnetic coil in the brake that opposes the permanent magnets. Electrically released brakes are polarity sensitive: the positive lead of the power supply must be connected to the positive lead of the brake, and the negative lead of the power supply must be connected to the negative lead of the brake. The power supply applied to the brake must be adjustable so that the optimum release voltage for each individual brake can be determined and set.

The following procedure describes how to set the adjustable power supply to the optimum release point of the brake. A volt-meter is required to perform the procedure.

CAUTION No power is applied to motor during this procedure. Power normally supplied by motor to brake control should be supplied by alternate method.

After control is adjusted per steps below, brake control may need to be fine tuned (adjusted) with motor running to compensate for any changes in supply voltage used.

1. With power off, connect the positive lead of the power supply to the positive lead of the brake and the negative lead of the power supply to the negative lead of the brake.
2. Connect a volt-meter to measure the voltage applied across the brake.
3. Adjust the power supply to its lowest possible output, then energize the power supply only, to apply power to the brake.
4. Starting from the low point, slowly increase the applied voltage until the brake armature disengages from the magnet. Note and record the applied voltage at this point.

- Continue to slowly increase the applied voltage until the armature re-engages the magnet. If the maximum voltage available from the supply does not cause the armature to re-engage, the armature should be manually assisted into engagement.

Note: If armature needs to be manually assisted, armature should be pressed on back side to make contact with friction face of magnet.

- With the armature re-engaged, slowly reduce the applied voltage until the armature disengages from the magnet. Note and record the applied voltage at this point.
- The optimum release point for the brake is half-way between the two recorded voltage readings. Adjust the supply to this optimum release voltage.

Note: The above procedure should be done by visually watching the armature move and may be repeated if necessary from Step 1 through Step 7.

If you have any problems during adjustments or any application questions arise, please contact Technical Support at 1-800-825-9050 Monday through Friday 7:30 a.m. - 4:30 p.m. central time.

F. Autogap Adjustment

Turn the power on to electrically release the brake. The armature should spring back approximately 1/32-inch as shown.

If the armature does not spring back, follow the autogap adjustment procedure as follows: (refer to Figure 4).

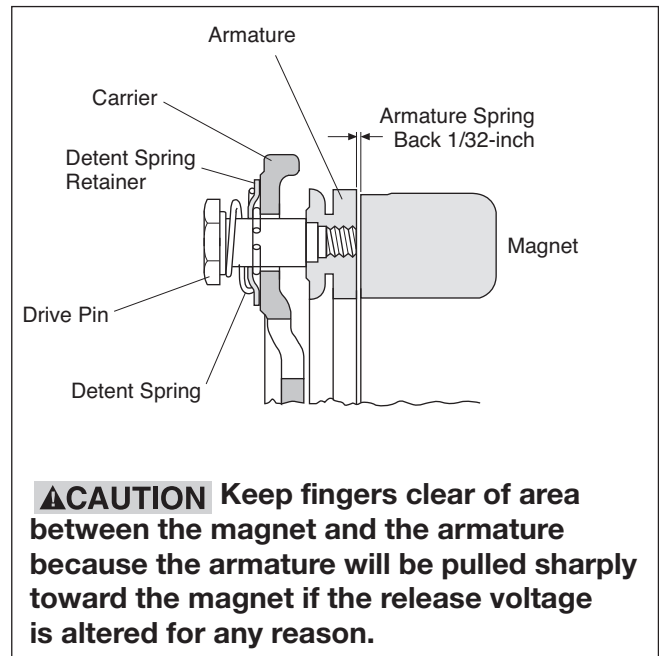

Figure 4

- With the brake power on, pull gently on the O.D. of the armature to separate it from the magnet by a 1/32-inch or greater airgap. **Do not pry. This could damage the components.**
- Slide the detent spring retainer on each drive pin until it bottoms against the carrier.

If armature cannot be moved, check voltage and polarity. (See Operating Instructions "Fails to Release" on page 7.)
- Push against the drive pins to push the armature into contact with the magnet.
- Release the drive pins and the armature will spring back approximately 1/32-inch. The armature gap will now be provided by the autogap mechanism.

Operating Instructions

A worn out Electrically Released Brake can lose its ability to produce torque. Consequently, it is imperative that the brake be inspected frequently for wear and to insure that it engages and disengages properly. The frequency of inspections is dictated by usage; a brake used in a high cycle rate and/or heavy load application must be inspected more often than one used less severely. Experience will determine proper inspection intervals.

The end of normal service will occur when the armature wears through the friction material and into the coil, causing an open circuit and failure to release when voltage is applied. Brake wear is determined by two checks. The first determines whether the brake is about to lose torque; the second ensures that the armature has not worn through the friction material, endangering the coil. If either of these checks indicates excessive wear, the unit should be replaced.

Check No. 1

Examine the three autogap release springs to assure that none of them are approaching total compression or if the distance from the underside of the drive pin head to the top of the detent cup washer is less than .062 inch, the brake should be replaced.

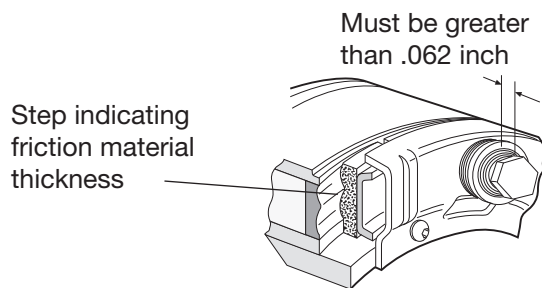

Check No. 1

Check No. 2

A step is machined on the O.D. of the brake magnet where the armature and magnet meet. This step is equal to the friction material thickness. When this step is completely covered by the armature with the brake engaged, the brake is worn out and should be replaced.

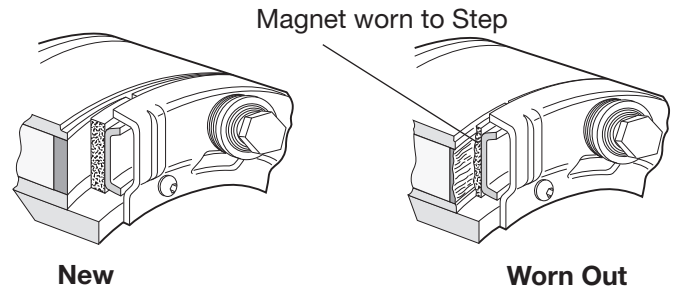

Check No. 2

After completing an inspection with the machine turned off, cycle it several times. If the Electrically Released Brake stopping time has more than doubled since the original set-up, this also indicates the brake is worn out and should be replaced.

Foreign Materials: If units are used on machinery where fine, abrasive dust, chips or grit are dispelled into the atmosphere, a protective screen over the unit may be necessary.

Where units are used near gear boxes or transmissions requiring frequent lubrications, means should be provided to protect the friction surfaces from oil and grease to prevent serious loss of torque by reducing the co-efficient of friction and swelling the friction material.

Oil and grease accidentally reaching the friction surfaces may be removed by wiping with a rag dampened with a suitable cleaner, which leaves no residue. In performing this operation, do not drench the friction material.

The drive pins should be kept free of foreign materials to ensure proper function of the brake.

Fails to Release: If the Electrically Released Brake does not release completely, make the following checks:

1. Check that the electrical connections (polarity) between the brake coil and the power supply are correct for the power supply being used.
2. Connect a DC voltmeter across the brake terminals. (Do not disconnect the leads to the terminals.) The voltmeter should indicate a voltage in the range of 75 to 110 volts.
3. The above checks are normally sufficient. Further checks may be made by checking the brake coil resistance.
 - a. Turn off the power to the brake.
 - b. Disconnect one lead from the coil to make sure the circuit is open.
 - c. Connect an ohmmeter across the brake terminals. The resistance should be as shown:

Brake Size	Coil Resistance at 20°C (±10%)
ER-375	447 OHMS
ER-475	310 OHMS
ER-650	235 OHMS

A very high or infinite resistance reading would indicate an open coil. A very low resistance would indicate a shorted coil. In either case, the unit should be replaced.

Wear Pattern: (See Figure 5) Wear grooves appear on the friction surfaces. This is a normal wear condition, and does not impair functioning of the unit. Never machine the friction surfaces to remove grooves or score marks resulting from normal wear.

There are two main wear parts, magnet and armature. When either is worn out, the complete brake must be replaced.

Heat: Excessive heat and high operating temperatures are causes of rapid wear. Air should be allowed to circulate around the unit as efficiently as possible, especially if the application requires fast, repetitive cycle operation.

If the above checks indicate that the proper voltage and current is being supplied to the coil, mechanical parts should be checked to assure that they are in good operating condition and are properly installed.

Wear Pattern

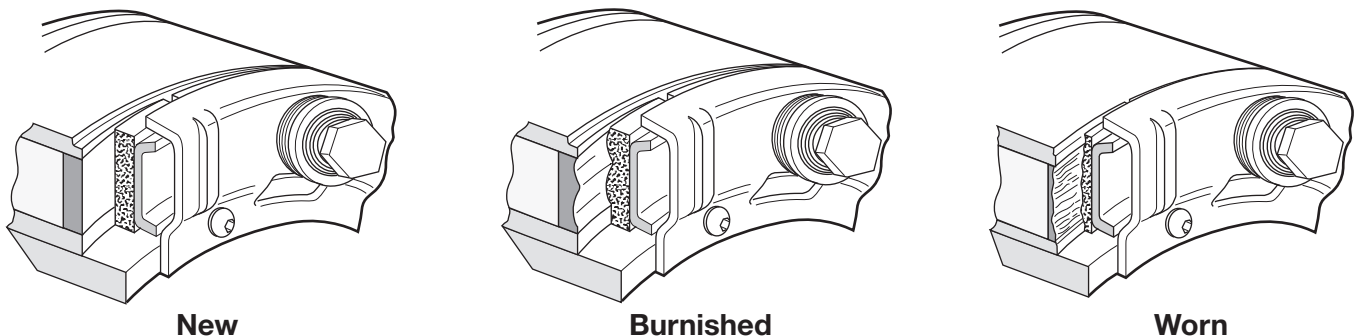
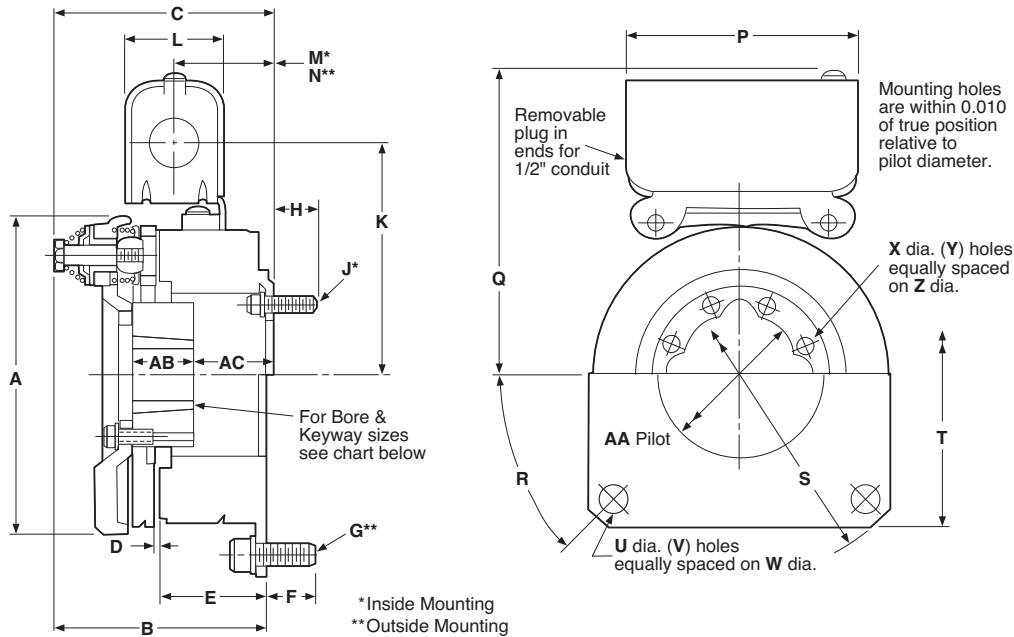

Figure 5

ER-375, ER-475, ER-650



All dimensions are nominal, unless otherwise noted.

Size	A Max.	B Max.	C Max.	D	E	F Max.	G	H Max.	J	K	L	M	N	P
375	4.078	2.583	2.583	.032	1.410	.600	5/16-18 UNC-3A	—	—	3.325	1.547	—	—	3.750
475	5.172	3.195	3.274	.031	1.630	.431	3/8-16 UNC-3A	.390	8-32	3.875	1.547	1.354	1.236	3.750
650	6.578	3.525	3.525	.032	1.880	.542	5/16-18 UNC-3A	.542	5/16-18 UNC-3A	4.800	1.547	—	—	3.750

Size	Q Max.	R	S	T Sq.	U	V	W Dia.	X	Y	Z Dia.	AA Dia.	AB	AC
375	4.505	—	<u>5.625</u> 5.623	—	<u>.350</u> .341	3	5.000	—	—	—	—	23/32	1-3/4
475	5.000	45°	<u>6.500</u> 6.498	5.000	<u>.419</u> .403	4	5.875	<u>.208</u> .201	8	2.375	<u>2.065</u> 2.062	29/32	1-3/16 I.M. 1-1/16 O.M.
650	5.844	45°	<u>8.000</u> 7.998	6.500	<u>.358</u> .338	4	7.250	<u>.358</u> .338	4	3.688	<u>2.822</u> 2.820	1-1/32	1-3/8

Mounting Requirements

Customer Shall Maintain:

1. Squareness of brake mounting face with armature hub shaft within .006 T.I.R.
2. Concentricity of brake mounting pilot diameter with armature hub shaft within .010 T.I.R.
3. If magnet mounting surface is a magnetic material, the magnet is to be insulated approximately 1/2" from that surface with a plate or spacers of non-magnetic material.
ER-375 available outside mounted only.

Bore and Keyway Dimensions

Size	Bore Dia.	Keyway
375	.501/.500	1/8 x 1/16
	.626/.625	3/16 x 3/32
475	.500 - .562	1/8 x 1/16
	.625 - .875	3/16 x 3/32
	.937 - 1.000	1/4 x 1/8
650	.500 - .562	1/8 x 1/16
	.625 - .875	3/16 x 3/32
	1.000 - 1.250	1/4 x 1/8
	1.312 - 1.375	5/16 x 5/32

Bushing Part Numbers

	Shaft Size	Part No.
Dodge 1008	1/2	180-0410
	9/16	180-0411
	5/8	180-0412
	11/16	180-0413
	3/4	180-0414
	13/16	180-0415
	7/8	180-0416
	15/16	180-0417
	1	180-0418
Dodge 1310	1/2	180-0421
	9/16	180-0422
	5/8	180-0423
	11/16	180-0424
	3/4	180-0425
	13/16	180-0426
	7/8	180-0427
	15/16	180-0428
	1	180-0429
	1-1/16	180-0430
	1-1/8	180-0431
	1-3/16	180-0432
	1-1/4	180-0433
	1-5/16	180-0434
	1-3/8	180-0435

Specifications

Electrically

Released Brake Size	Voltage DC	Static Torque	Max. Speed	Total Weight
ER-375	90	10.5 lb. Ft.	5000	4.5 lbs.
ER-475	90	21 lb. Ft.	4500	6.3 lbs.
ER-650	90	56 lb. Ft.	3600	13.2 lbs.

Electrically Released Brake Size	Average Wt. - lbs.		Inertia - WR ²	
	Armature & Carrier	Hub	Armature & Carrier	Hub
ER-375	.60 lbs	.49	.010 lb.ft. ²	.001
ER-475	1.13 lbs.	.78	.072 lb.ft. ²	.006
ER-650	2.3 lbs.	1.6	.106 lb.ft. ²	.020

ER-375, ER-475, ER-650

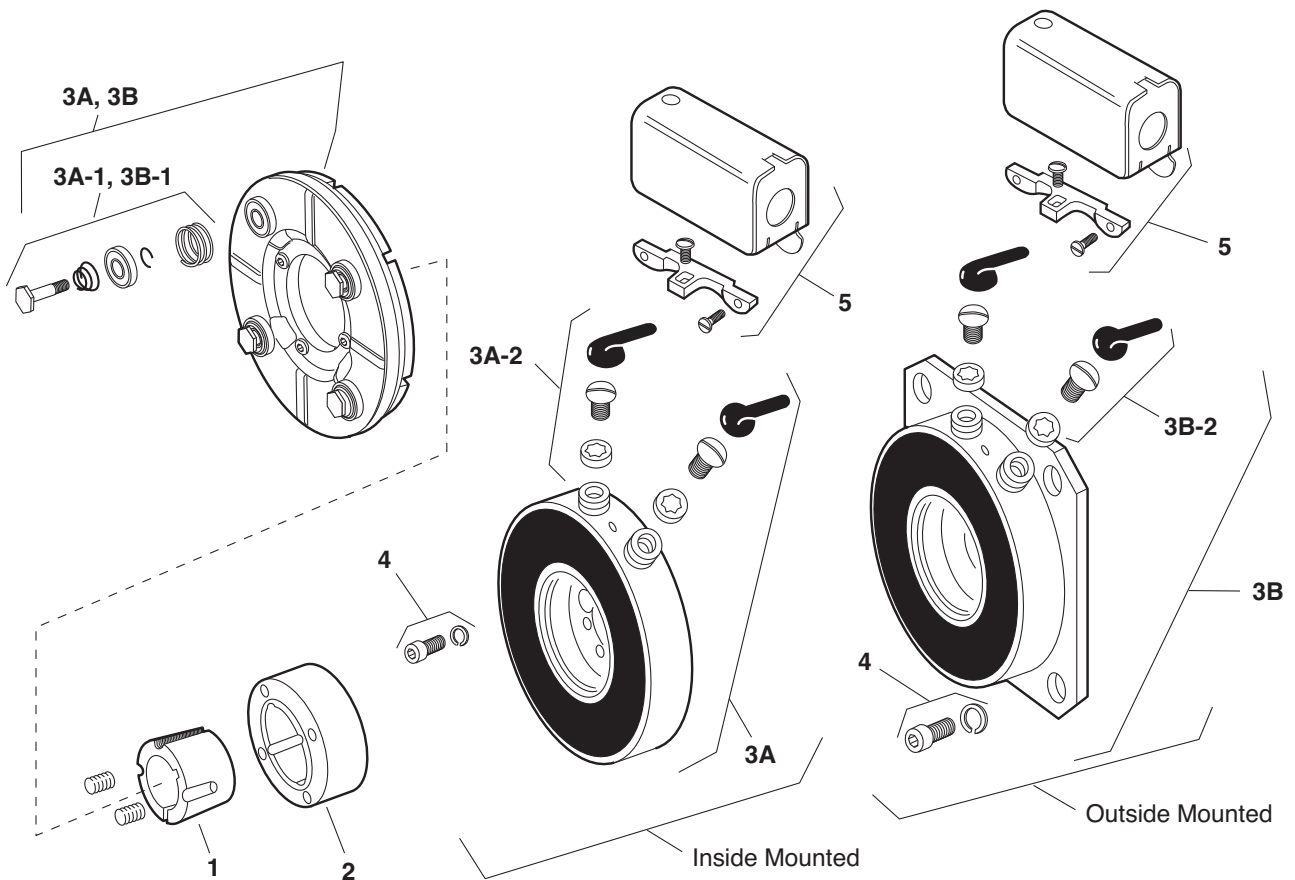

ER-375 (Drawing I-25766)
ER-475 (Drawing I-25765)
ER-650 (Drawing I-25767)



Component Parts

Item	Description	ER-375		ER-475		ER-650	
		Part Number	Qty	Part Number	Qty	Part Number	Qty
1	†Bushing			180-0410-0418 (1/2" to 1" Bore)	1	180-0421-0435 (1/2" to 1-3/8" Bore)	1
2	Hub			540-0849	1	540-0848	1
	1/2" Bore	540-0846	1				
	5/8" Bore	540-0847	1				
3A	Magnet and Armature (Inside Mounted, 90 Volt) Sold only in matched pairs*			5255-5	1	5256-6	1
3A-1	Autogap Accessory			5391-101-003	4	5392-101-003	4
3A-2	Terminal Accessory			5103-101-002	1	5103-101-002	1
3B	Magnet and Armature (Outside Mounted, 90 Volt) Sold only in matched pairs*			5255-6	1	5256-7	1
		5254-1	1				
3B-1	Autogap Accessory	5390-101-002	3	5391-101-003	4	5392-101-003	1
3B-2	Terminal Accessory	5103-101-002	1	5103-101-002	1	5103-101-002	1
4	Mounting Accessory						
	Inside Mount			5255-101-001	1	5256-101-003	1
	Outside Mount	5254-101-002	1	5255-101-002	1	5256-101-003	1
5	Conduit Box	5200-101-010	1	5200-101-010	1	5200-101-010	1

† See page 9 for specific part numbers.

* Magnets and armatures sold only in pre-burnished sets to assure rated torque available upon installation.

These units, when used with the correct Warner Electric conduit box, meet the standards of UL508 and are listed under guide card #NMTR2, file #59164.

How to Order

1. Specify bore size.
2. Specify Normal or Heavy Duty.

Example

ER-650 Electrically Released Brake per I-25767,
7/8" bore.

Warranty

Warner Electric LLC warrants that it will repair or replace (whichever it deems advisable) any product manufactured and sold by it which proves to be defective in material or workmanship within a period of one (1) year from the date of original purchase for consumer, commercial or industrial use.

This warranty extends only to the original purchaser and is not transferable or assignable without Warner Electric LLC's prior consent.

Warranty service can be obtained in the U.S.A. by returning any defective product, transportation charges prepaid, to the appropriate Warner Electric LLC factory. Additional warranty information may be obtained by writing the Customer Satisfaction Department, Warner Electric LLC, 449 Gardner Street, South Beloit, Illinois 61080, or by calling 815-389-3771.

A purchase receipt or other proof of original purchase will be required before warranty service is rendered. If found defective under the terms of this warranty, repair or replacement will be made, without charge, together with a refund for transportation costs. If found not to be defective, you will be notified and, with your consent, the item will be repaired or replaced and returned to you at your expense.

This warranty covers normal use and does not cover damage or defect which results from alteration, accident, neglect, or improper installation, operation, or maintenance.

Some states do not allow limitation on how long an implied warranty lasts, so the above limitation may not apply to you.

Warner Electric LLC's obligation under this warranty is limited to the repair or replacement of the defective product and in no event shall Warner Electric LLC be liable for consequential, indirect, or incidental damages of any kind incurred by reason of the manufacture, sale or use of any defective product. Warner Electric LLC neither assumes nor authorizes any other person to give any other warranty or to assume any other obligation or liability on its behalf.

WITH RESPECT TO CONSUMER USE OF THE PRODUCT, ANY IMPLIED WARRANTIES WHICH THE CONSUMER MAY HAVE ARE LIMITED IN DURATION TO ONE YEAR FROM THE DATE OF ORIGINAL CONSUMER PURCHASE. WITH RESPECT TO COMMERCIAL AND INDUSTRIAL USES OF THE PRODUCT, THE FOREGOING WARRANTY IS IN LIEU OF AND EXCLUDES ALL OTHER WARRANTIES, WHETHER EXPRESSED OR IMPLIED BY OPERATION OF LAW OR OTHERWISE, INCLUDING, BUT NOT LIMITED TO, ANY IMPLIED WARRANTIES OF MERCHANTABILITY OR FITNESS.

Some states do not allow the exclusion or limitation of incidental or consequential damages, so the above limitation or exclusion may not apply to you. This warranty gives you specific legal rights and you may also have other rights which vary from state to state.

Changes in Dimensions and Specifications

All dimensions and specifications shown in Warner Electric catalogs are subject to change without notice. Weights do not include weight of boxing for shipment. Certified prints will be furnished without charge on request to Warner Electric.



Warner Electric LLC
449 Gardner Street • South Beloit, IL 61080
815-389-3771 • Fax: 815-389-2582
www.warnerelectric.com
An Altra Industrial Motion Company